

ETAP I

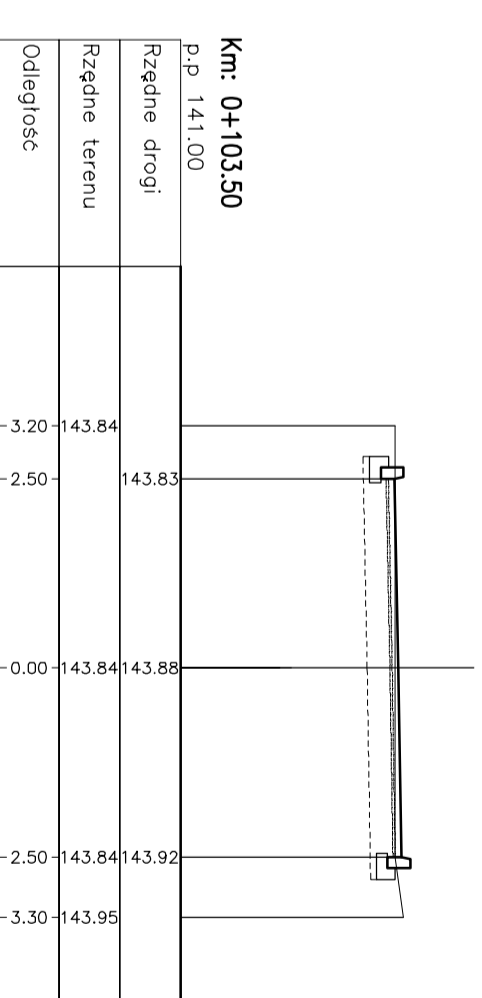
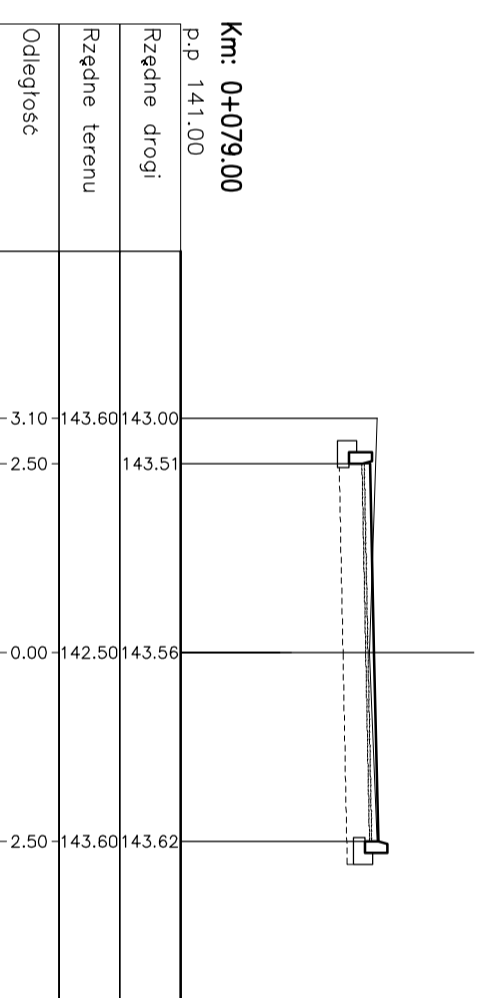
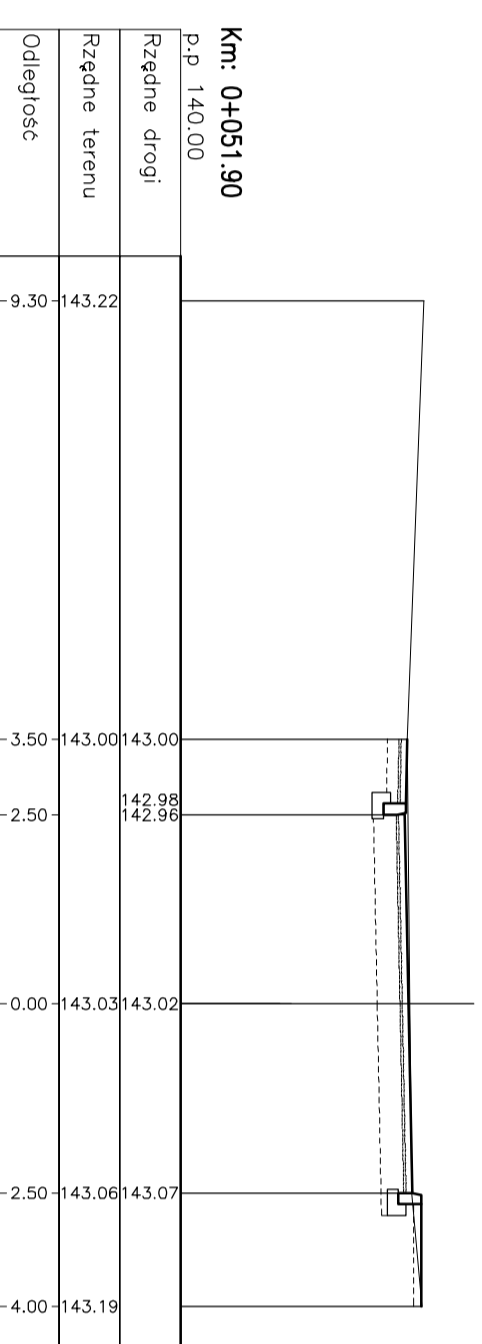
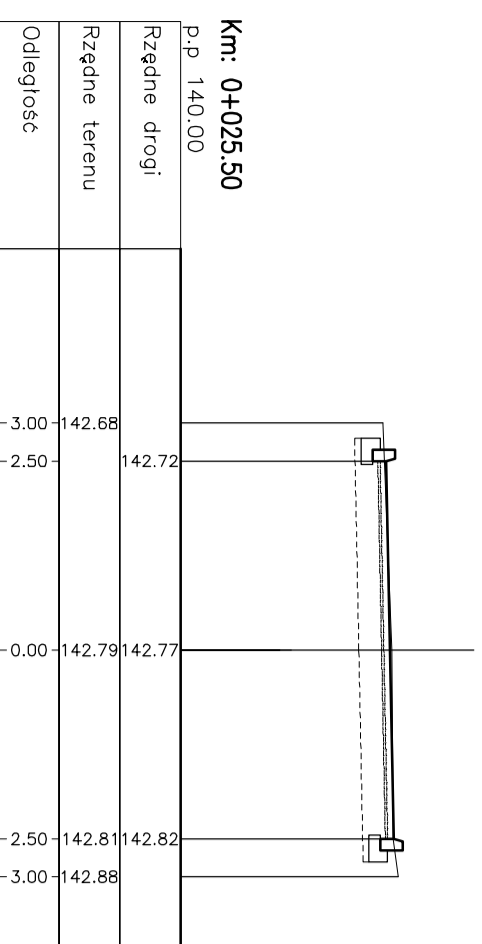
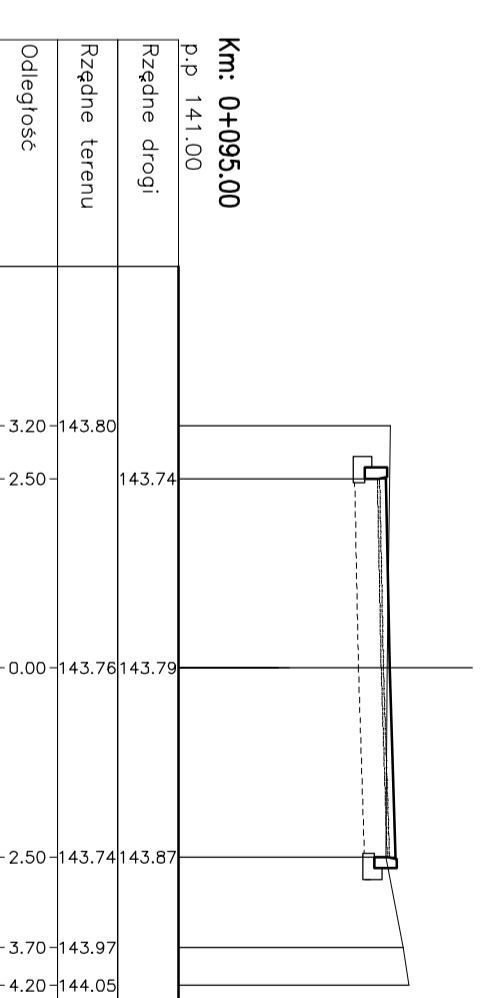
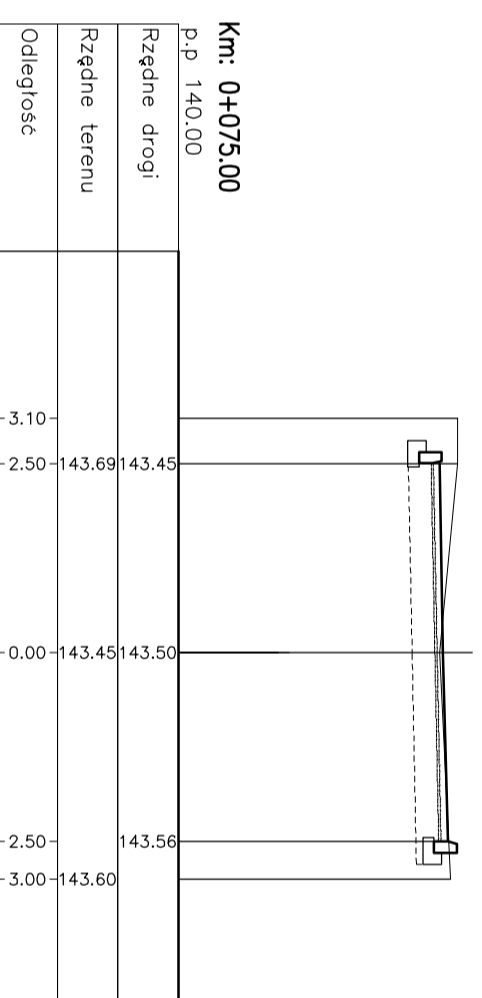
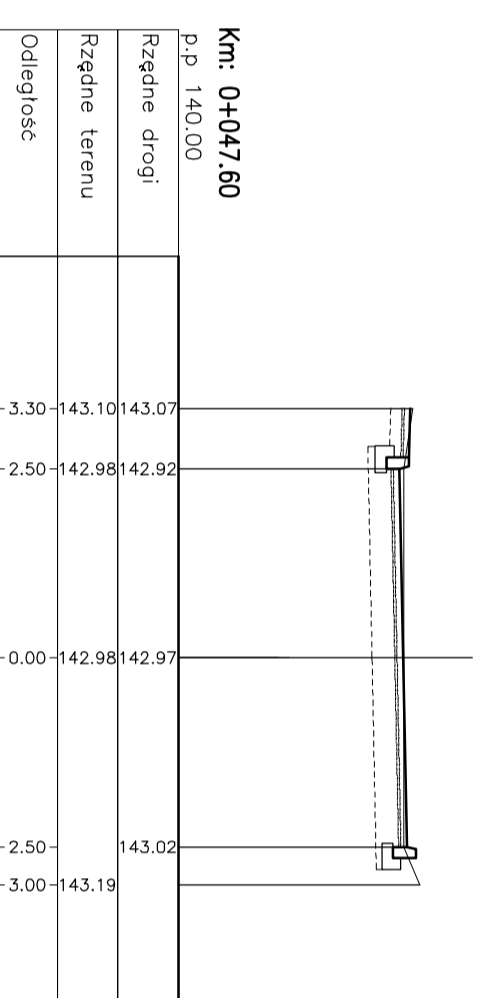
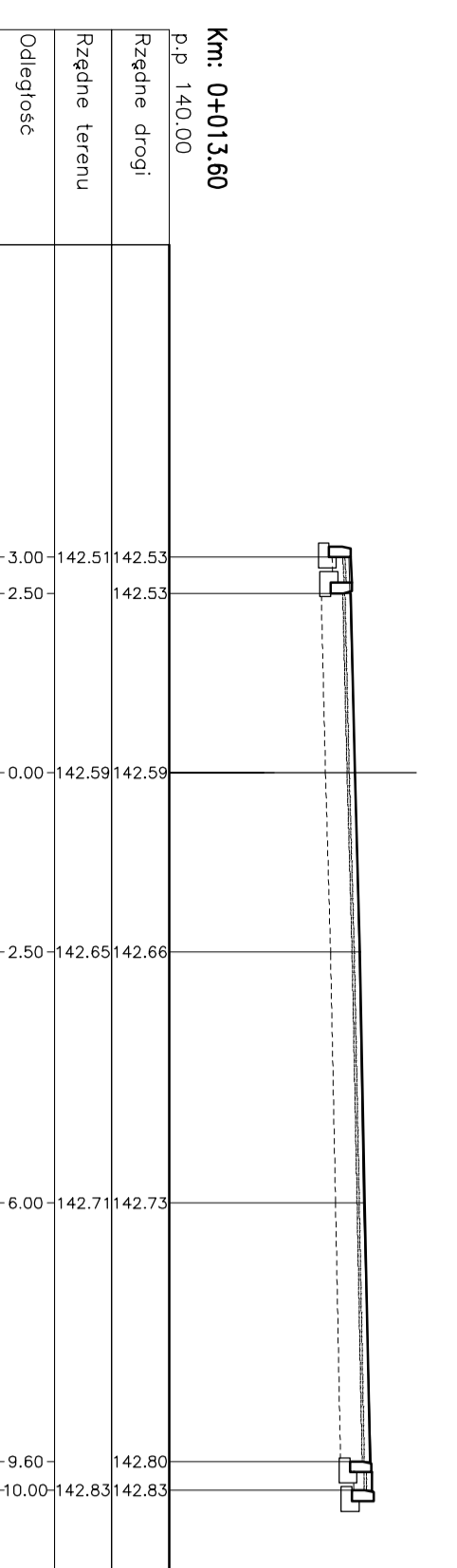
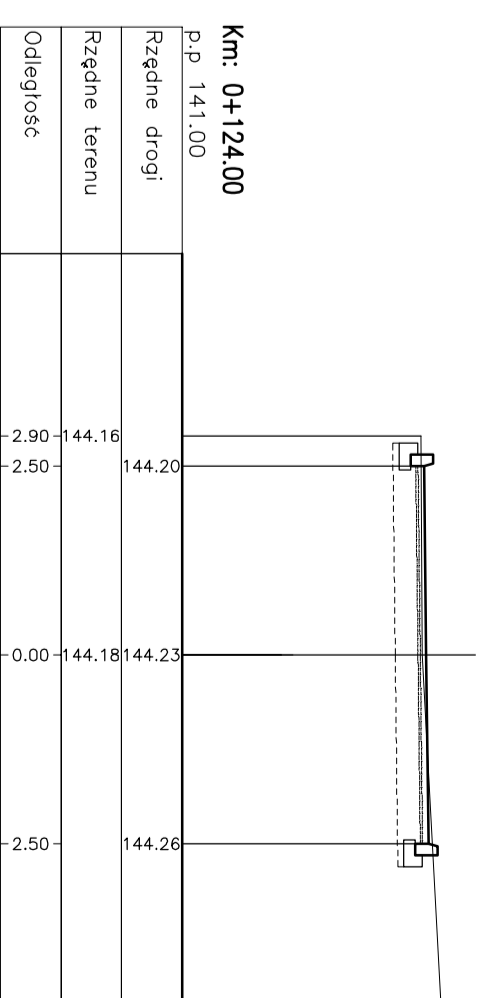
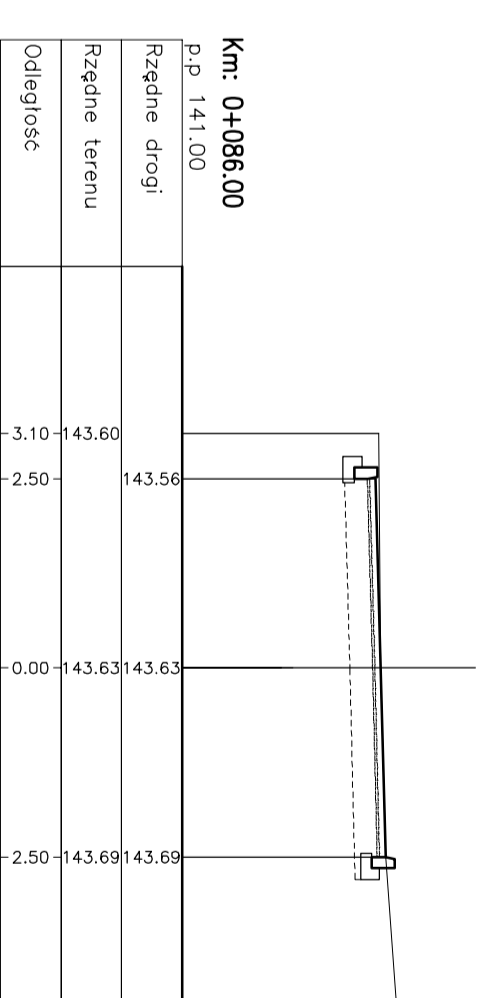
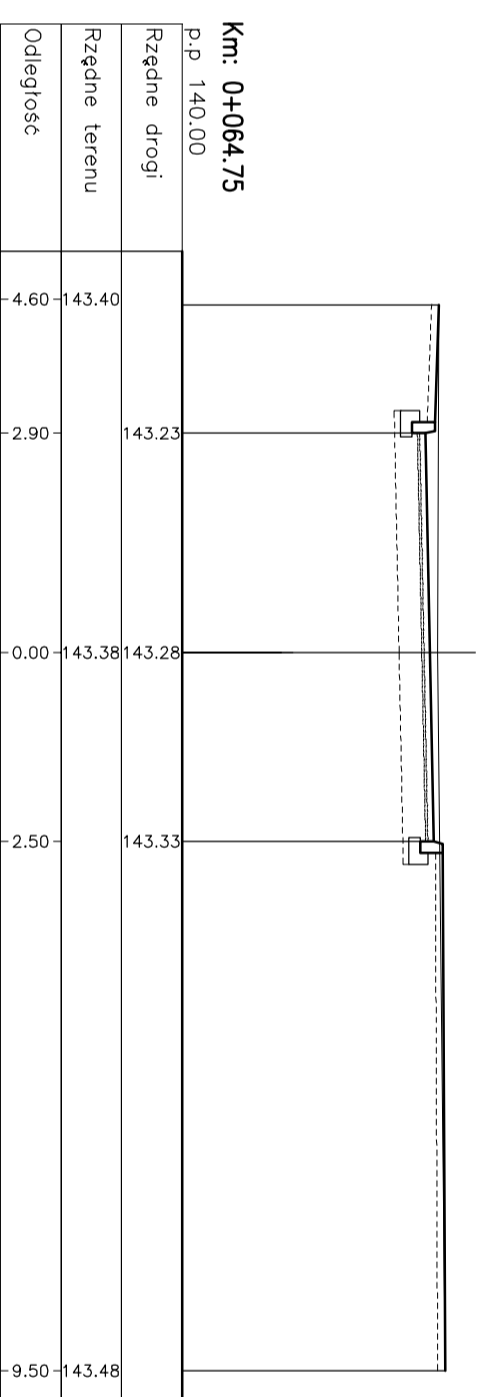
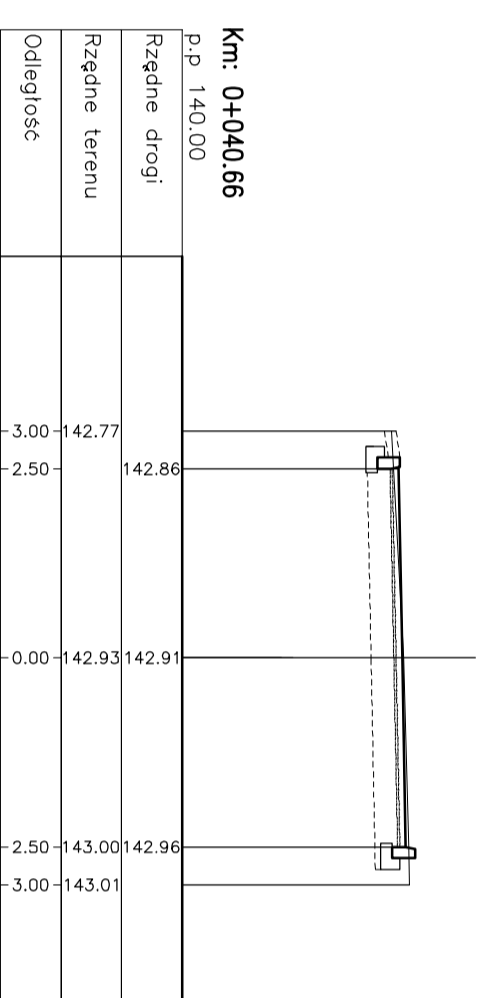
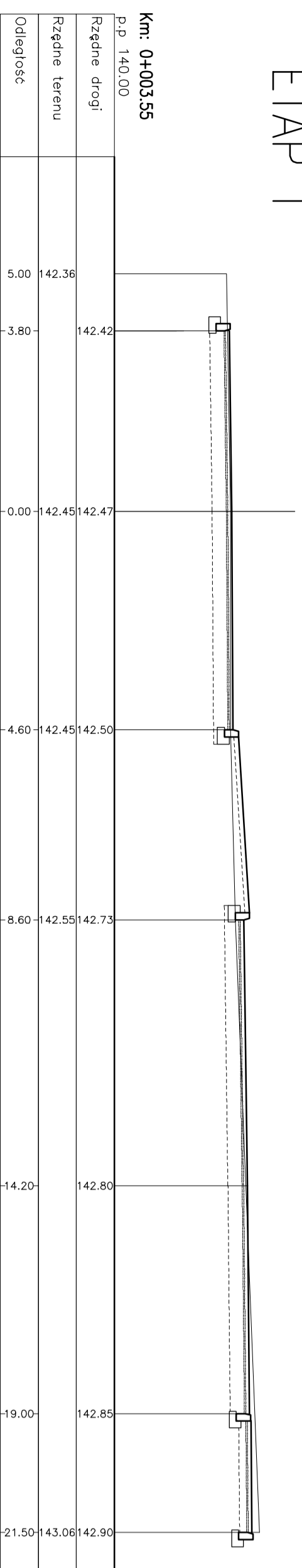

PRACOWNIA PROJEKTOWO-WYKONAWCZA DWD JERZY KALOŃSKI		Nr projektu	
PRZEBUDOWA UL. RADOŃNEJ		5.1	
W SZCZECINKU		1:100	
GMINA MIASTO SZCZECINEK		Data: 2013	
DROGI ODMIENIENE BRZOZI		Skala: 1:100	
PRZEKROJE POPRZECZNE		Data: MARZEC 2013	
Drogi		Inicjator: 141-4879-Kalodnik	
Wzrost: 1:100		Zamówca: 28/2014/0000/14	
Projektant: Inż. Bogdan Wajuda		Data: MARZEC 2013	